

Videojet® 3320

Laser Marking System

Laser.

Ink Jet.

Thermal Transfer.

Labelers.

Track & Trace.

Supplies.

Parts & Service.



The Videojet 3320 laser marking system is an easy-to-use, flexible to integrate, high speed 30-Watt CO2 laser marker. This compact, flexible system provides permanent, high quality codes with low maintenance and operating costs. The Videojet 3320 is well-suited for applications in the food, beverage, pharmaceutical, cosmetics, automotive, electronics and extrusion markets.

High speed, high quality marks

- Fastest 30-Watt laser marking system in its class
- Speeds up to 1,300 characters per second and 49 feet per second (15 m/sec.)
- Steered beam technology delivers high quality "continuous" codes, even at high speeds

More information at high speeds

- Multi-line text, machine readable codes, graphics
- Unlimited font, graphics and format flexibility

Easy operation and maintenance

- Handheld or external PC control options
- Intuitive software allows for quick and easy job edits
- Efficient, fan cooled design results in long tube life, with low maintenance and operating costs

Easy integration

- Flexible standard components
- Small footprint

VIDEOJET®
Uptime Peace of Mind®



Marking Speed

Up to 1,300 characters/sec. (application dependent)

Line Speed

Up to 49 feet/sec. (15 m/sec.) (application dependent)

Marking Field

Stationary products: from 1.7 x 1.7 to 7.0 x 7.0 inches² standard (44 x 44 to 177 x 177 mm²), and options

Moving products: maximum height from 1.7 to 7.0 inches standard (44 to 177 mm), depending on focus options

Marking Formats

Standard industrial fonts (Type 1 Windows® TrueType®)

Machine readable codes (OCR, 2D-matrix, etc.)

Bar codes: BC25, BC251, BC39, BC128, EAN128, EAN13, UPC_A, RSS14, RSS14 Truncated, RSS14 Stacked, RSS14 Stacked Omnidirectional, RSS Limited, RSS Expanded, etc.

Graphics, logos, symbols, etc.

Linear, circular, angular, reverse, rotate

Sequential and batch numbering

Automatic date, time, shift coding, real-time clock function

Laser Tube

Single sealed CO2 laser, power class 30-Watt

Beam Deflection

Steered beam with digital high-speed galvanometer scanners

Focusing

Precision lens system

Standard focal lengths: 2.5 / 3.75 / 5.0 / 7.5 / 10.0 inch (64 / 95 / 127 / 190 / 254 mm), options

Dimensions

Marking Unit

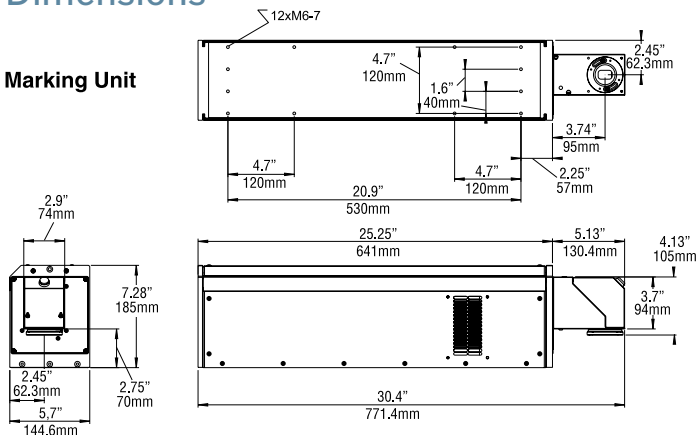

Supply Unit

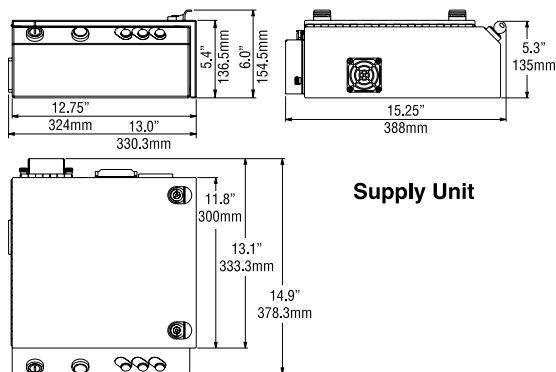

Handheld Controller

Ethernet-enabled graphic remote control

Fast and intuitive code setting, system configuration and operation

Status and alarm indication with troubleshooting messages

Excellent display readability

Smart Graph Software

Graphical user interface under Windows® 2000/XP for intuitive and quick generation of complete marking jobs on external PCs

Full feature text/data/graphics/parameter editor

Easy access to standard CAD and graphics programs by convenient import functions

WYSIWYG

Multiple security levels with configurable user rights, password protected

Smart Graph Com Software

ActiveX communication interface to PC networks, digital I/O subsystems

Language Capabilities

Selectable, permanently installed: English, Chinese, French, German, Italian, Japanese, Spanish and options

Communication

Ethernet, TCP/IP; optionally RS232

Inputs for encoders and product detector triggers

3 inputs/ 7 outputs for start/ stop signals, machine/ operator interlocks, alarm outputs; with additional I/Os extensible

Customer-specific solutions

Integration

Direct integration into complex production lines via interface

Flexible beam delivery options (beam unit/beam turning unit)

Electrical Requirements

100-240 V (autorange), ~50/60 Hz, 1 PH, 0.70 kW

Cooling System

Air cooled

Environment

Temperature range 40-105° F (5-40° C)

Humidity 10%-90%, non-condensing

Sealing and Safety Standards

IP54, optional IP65; LASER CLASS 4 product

(acc. to DIN EN 60825-1: 05/2008)

Approximate Weight

73 lbs. (33 kg)

Applicable Certifications

CE, ROHS, CSA, UL, TÜV



800-843-3610

www.videojet.com / info@videojet.com

Videojet Technologies Inc. / 1500 Mittel Blvd.
Wood Dale IL 60191-1073 / USA

Phone 630-860-7300 Fax 800-582-1343

